

P P T 8 8 0 0 w i t h
W i n d o w s M o b i l e 2 0 0 3
f o r P o c k e t P C s



symbol[®]

© 2003 SYMBOL TECHNOLOGIES, INC. All rights reserved.

Symbol reserves the right to make changes to any product to improve reliability, function, or design.

Symbol does not assume any product liability arising out of, or in connection with, the application or use of any product, circuit, or application described herein.

No license is granted, either expressly or by implication, estoppel, or otherwise under any patent right or patent, covering or relating to any combination, system, apparatus, machine, material, method, or process in which Symbol products might be used. An implied license only exists for equipment, circuits, and subsystems contained in Symbol products.

Symbol, the Symbol logo and Spectrum24 are registered trademarks of Symbol Technologies, Inc. Bluetooth is a trademark of Bluetooth SIG, Inc. Other product names mentioned in this manual may be trademarks or registered trademarks of their respective companies and are hereby acknowledged.

Symbol Technologies, Inc.
One Symbol Plaza
Holtsville, N.Y. 11742-1300
<http://www.symbol.com>

Patents

This product is covered by one or more of the following U.S. and foreign Patents:

U.S. Patent No. 4,593,186; 4,603,262; 4,607,156; 4,652,750; 4,673,805; 4,736,095;
4,758,717; 4,760,248; 4,806,742; 4,816,660; 4,845,350; 4,896,026; 4,897,532; 4,923,281; 4,933,538;
4,992,717; 5,015,833; 5,017,765; 5,021,641; 5,029,183; 5,047,617; 5,103,461; 5,113,445; 5,130,520;
5,140,144; 5,142,550; 5,149,950; 5,157,687; 5,168,148; 5,168,149; 5,180,904; 5,216,232; 5,229,591;
5,230,088; 5,235,167; 5,243,655; 5,247,162; 5,250,791; 5,250,792; 5,260,553; 5,262,627; 5,262,628;
5,266,787; 5,278,398; 5,280,162; 5,280,163; 5,280,164; 5,280,498; 5,304,786; 5,304,788; 5,306,900;
5,324,924; 5,337,361; 5,367,151; 5,373,148; 5,378,882; 5,396,053; 5,396,055; 5,399,846; 5,408,081;
5,410,139; 5,410,140; 5,412,198; 5,418,812; 5,420,411; 5,436,440; 5,444,231; 5,449,891; 5,449,893;
5,468,949; 5,471,042; 5,478,998; 5,479,000; 5,479,002; 5,479,441; 5,504,322; 5,519,577; 5,528,621;
5,532,469; 5,543,610; 5,545,889; 5,552,592; 5,557,093; 5,578,810; 5,581,070; 5,589,679; 5,589,680;
5,608,202; 5,612,531; 5,619,028; 5,627,359; 5,637,852; 5,664,229; 5,668,803; 5,675,139; 5,693,929;
5,698,835; 5,705,800; 5,714,746; 5,723,851; 5,734,152; 5,734,153; 5,742,043; 5,745,794; 5,754,587;
5,762,516; 5,763,863; 5,767,500; 5,789,728; 5,789,731; 5,808,287; 5,811,785; 5,811,787; 5,815,811;
5,821,519; 5,821,520; 5,823,812; 5,828,050; 5,848,064; 5,850,078; 5,861,615; 5,874,720; 5,875,415;
5,900,617; 5,902,989; 5,907,146; 5,912,450; 5,914,478; 5,917,173; 5,920,059; 5,923,025; 5,929,420;
5,945,658; 5,945,659; 5,946,194; 5,959,285; 6,002,918; 6,021,947; 6,029,894; 6,031,830; 6,036,098;
6,047,892; 6,050,491; 6,053,413; 6,056,200; 6,065,678; 6,067,297; 6,082,621; 6,084,528; 6,088,482;
6,092,725; 6,101,483; 6,102,293; 6,104,620; 6,114,712; 6,115,678; 6,119,944; 6,123,265; 6,131,814;
6,138,180; 6,142,379; 6,172,478; 6,176,428; 6,178,426; 6,186,400; 6,188,681; 6,209,788; 6,209,789;
6,216,951; 6,220,514; 6,243,447; 6,244,513; 6,247,647; 6,308,061; 6,250,551; 6,295,031; 6,308,061;
6,308,892; 6,321,990; 6,328,213; 6,330,244; 6,336,587; 6,340,114; 6,340,115; 6,340,119; 6,348,773;
6,380,949; 6,394,355; D305,885; D341,584; D344,501; D359,483; D362,453; D363,700; D363,918;
D370,478; D383,124; D391,250;
D405,077; D406,581; D414,171; D414,172; D418,500; D419,548; D423,468; D424,035;
D430,158; D430,159; D431,562; D436,104.
Invention No. 55,358; 62,539; 69,060; 69,187, NI-068564 (Taiwan); No. 1,601,796; 1,907,875; 1,955,269
(Japan); European Patent 367,299; 414,281; 367,300; 367,298; UK 2,072,832; France 81/03938; Italy
1,138,713
rev. 06/02

Introduction

Congratulations on your purchase of Symbol Technologies' PPT 8800 with Windows® Mobile 2003 Software for Pocket PCs. Its unique combination of features make this product superior for use in a wide range of applications. These features include:

- Small rugged lightweight form factor
- Microsoft® Windows® Mobile software
- RF communication via Symbol's Spectrum24® wireless network and/or Bluetooth™
- Printing support
- Scanning capability
- Standard 6-key and 15-key backlit keypad configurations
- Transflective color LCD display with digitizer.

About This Guide

This guide describes how to set up and use the terminal. The term PPT 8800 Series refers to the batch, Spectrum24 and Bluetooth versions of the terminal. Specific topics covered include:

- [Accessories on page 2](#)
- [Parts of the Terminal on page 3](#)
- [Getting Started on page 5](#)
- [Scanning on page 14](#)
- [Using a Headset on page 15](#)
- [Resetting the Terminal on page 15](#)
- [Host Communications on page 17](#)
- [Maintenance on page 19](#)
- [Troubleshooting on page 20](#)
- [Regulatory Information on page 27](#)
- [Warranty on page 25](#)
- [Service Information on backcover.](#)



The *PPT 8800 with Windows Mobile 2003 Software for Pocket PCs 2003 Product Reference Guide* (p/n 72-63154-XX) details the applications available for the terminal. For the latest version of this guide, visit: <http://www.symbol.com/manuals>.

Accessories

The following optional accessories will be available from Symbol:

- Spare lithium-ion rechargeable battery
- Larger capacity lithium-ion rechargeable battery kit
- Single-Slot Serial Cradle
- Four-Slot Serial Cradle
- Four-Slot Ethernet Cradle
- Holster(s) or case
- Stylus or tethered stylus
- Serial charging cable
- Universal cable cup for attachable cables:
 - attachable power supply and line cord
 - Printer cable options
 - DEX cable
 - Auto charging cable
 - USB cable
- Pistol grip handle
- Magnetic stripe reader
- UBC adapter
- Vehicle cradle.

Parts of the Terminal

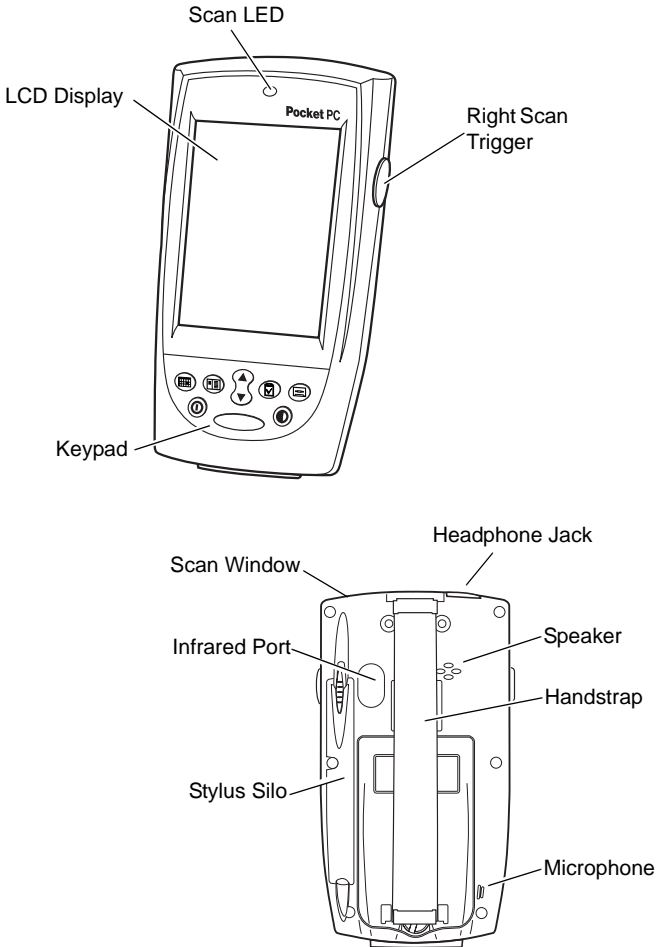

Parts of the Terminal (continued)

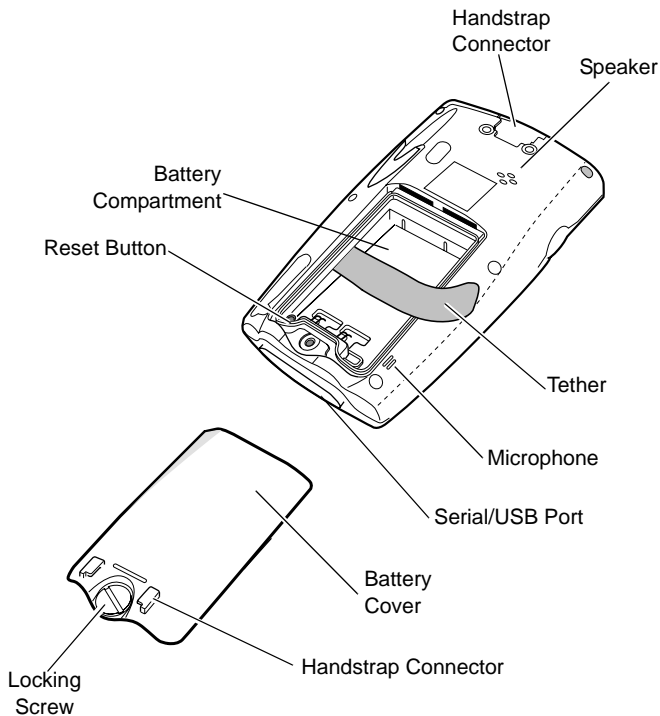

Getting Started

Before using the PPT 8800, perform the basic setup procedures:

- Install and charge the main battery and backup battery
- Start the terminal
- Initiate the network connection.

Installing the Battery

Note: Also use the following procedures for installing the optional larger capacity lithium-ion battery and battery cover.

1. Turn the locking screw counterclockwise until the battery cover releases from the terminal.
2. Lift the battery cover away from the terminal.
3. Insert the battery in the battery compartment with the battery tether positioned as shown, ensuring that the battery snaps into place.

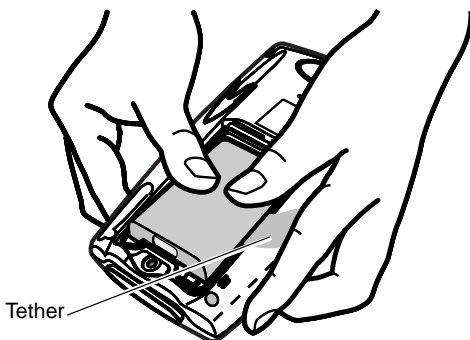

4. Replace the battery cover by inserting the top first, then pressing the bottom in firmly.

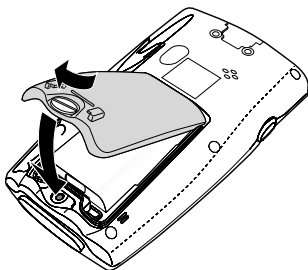

5. Turn the locking screw clockwise to secure the cover to the terminal.

Charging the Battery

Before using your terminal for the first time, charge the main battery in the terminal for approximately 2 1/2 hours, using a cradle or the serial charging cable. The larger capacity battery charges in approximately 5 hours.

Your terminal is equipped with a memory backup battery which automatically charges from the fully-charged main battery. This backup battery retains data in memory for 20 minutes when the terminal's battery is removed, and takes about 24 hours to charge when you first use your terminal.

Note: If the main battery is removed before the backup battery is fully charged, data may be lost. For this reason, **DO NOT** remove the battery within the first 24 hours of use.

Charging the Battery Using the Serial Charging Cable

Charge the main battery using the Serial Charging Cable. The standard battery charges in approximately 2 1/2 hours. The larger capacity battery charges in approximately 5 hours.

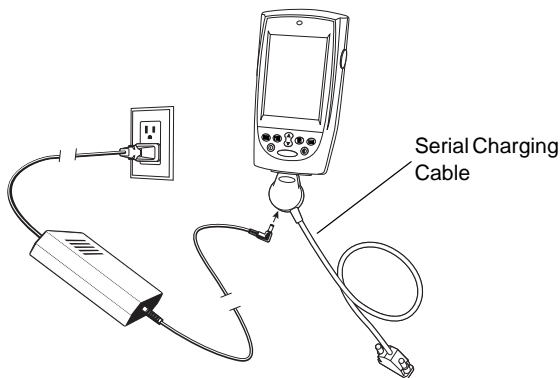

Charging the Battery Using a Cradle

Note: To ensure the quickest charging time, turn the terminal off while charging.

Charge the main battery using the UBC Adapter or the CRD 8800 Single-Slot Cradle. The battery charges in approximately 2 1/2 hours. For more information, see the setup instructions in the *CRD 8800 Single-Slot Cradle Quick Reference Guide*.

Charging a Spare Battery

Charge a spare battery using the UBC Adapter or the CRD 8800 Single-Slot Cradle. For more information on charging with the cradle, see the setup instructions in the *CRD 8800 Single-Slot Cradle Quick Reference Guide*.

Starting the Terminal

Press the  button to turn on the terminal. If the terminal does not power on, perform a hard reset. See [Performing a Hard Reset on page 16](#).

As the terminal initializes its unique Flash File system, the Symbol splash screen displays for about a minute followed by the calibration screen. Note that these screens also appear every time you perform a hard reset.

Calibrating the Screen



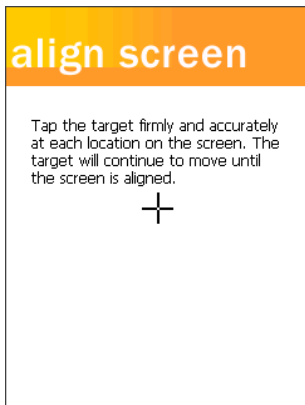

To align your terminal so the cursor on the touch screen aligns with the tip of your stylus:

1. If necessary, adjust the backlight on the terminal so the screen is readable (see [Adjusting the Backlight on page 9](#)).
2. Remove the stylus from the stylus silo.
3. Tap the center of each target that appears on the *Align screen* with the tip of the stylus.



4. Follow the directions on the screen which explains how to use the stylus and pop-up menus, and allows you to set your time zone.

Q u i c k R e f e r e n c e

Note: To re-calibrate the screen at anytime, press  +  on a 15-key terminal or press  +  on a Standard 6-key terminal to launch the calibration screen application.

Using the Power Button





The  button turns the terminal on and off and controls the display and keypad backlight.

Adjusting the Backlight

Note: Keys are user programmable.





Standard 6-Key Configuration

Use the key combinations below to adjust the backlights.

Keys	Description
Press and hold 	Turns the display backlight and keypad backlight on and off.
	When both backlights are off, the backlights turn on in the following order when the button is held: First the display backlight turns on, continue to hold and the keypad backlight turns on. When either backlight is on, the backlights turn off when the button is pressed and held.
Press  + 	Decrease backlight (decrease brightness).
Press  + 	Increase backlight (increase brightness).

15-Key Configuration

Use the key combinations below to adjust the backlights.

Keys	Description
Press and hold 	Turns the display backlight and keypad backlight on and off. When both backlights are off, the backlights turn on in the following order when the button is held: First the display backlight turns on, continue to hold and the keypad backlight turns on. When either backlight is on, the backlights turn off when the button is pressed and held.
Press  + 	Decrease display backlight (decrease brightness).
Press  + 	Increase display backlight (increase brightness).

Using the Keypad

The terminal has two keypad configurations: A Standard 6-key and a 15-key configuration.

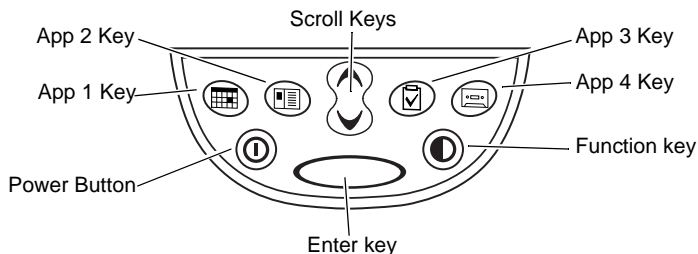

Standard 6-Key Configuration

Q u i c k R e f e r e n c e

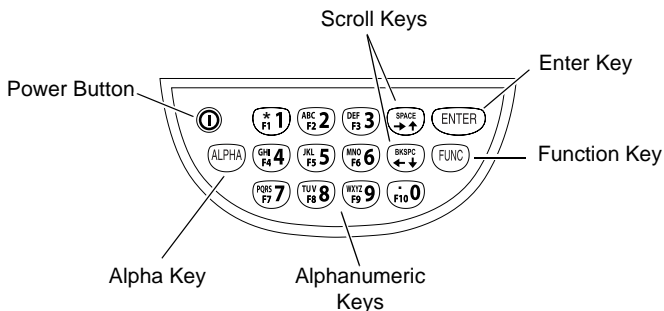

15-Key Configuration

Using the Stylus

The stylus selects items and enters information. The stylus functions as a mouse.

- **Tap:** Touch the screen once with the stylus to open option buttons and select menu items.
- **Drag:** Hold the stylus on the screen and drag across the screen to select text and images. Drag in a list to select multiple items.
- **Tap and Hold:** Tap and hold the stylus on an item to see a list of actions available for that item. On the pop-up menu that appears, tap the action you want to perform.

Today Screen

When you turn on your terminal for the first time each day (or after 4 hours of inactivity), the Today screen appears. You can also

display it by tapping *Start - Today*. On the Today screen, you can see important information for the day.

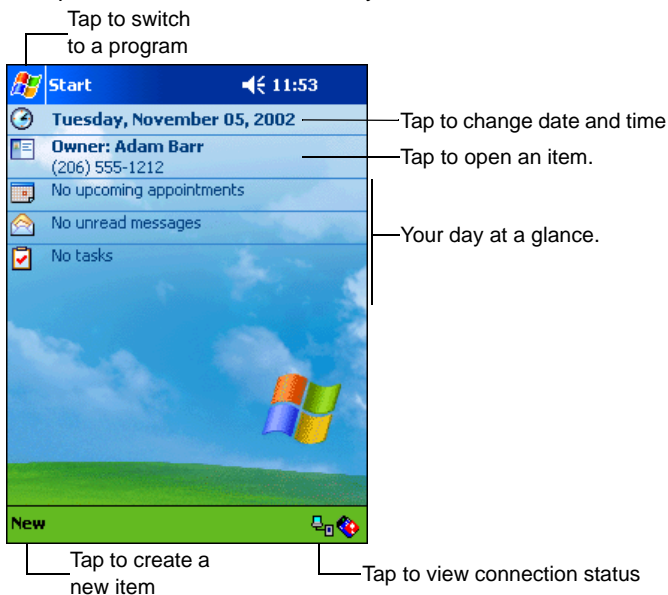

Note: Today screen may vary depending on your terminal configuration.

Navigation Bar and Command Bar

The navigation bar at the top of the screen displays the active program and current time, and allows you to switch to programs

Q u i c k R e f e r e n c e

and close screens. The command bar at the bottom of the screen contains menus and buttons to perform tasks in programs.

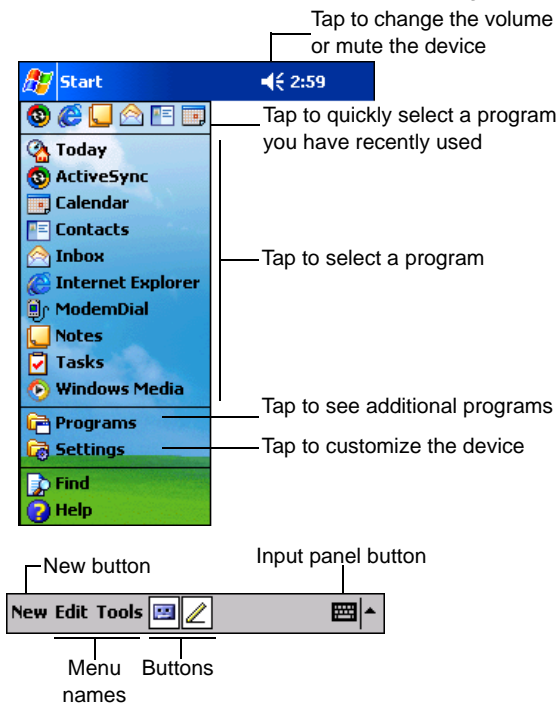

The Start Menu is customizable. Tap *Start - Settings - Menus*. Use the *Start Menu* tab to check what items should appear on the menu.

Input Methods

Enter information in any program by typing with the keyboard, or use the input panel to type with the soft keyboard, write using Block Recognizer, Letter Recognizer or Transcriber. In any case, the characters appear as typed text on the screen.

To show or hide the input panel, tap the Input Panel button. Tap the arrow next to this button to view input methods.

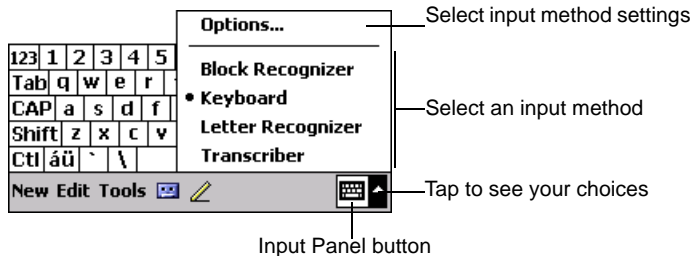

When you use the input panel, your terminal anticipates the word you are typing or writing and displays it above the input panel. When you tap the displayed word, it is inserted into your text at the insertion point. The more you use your terminal, the more words it learns to anticipate. Refer to the *PPT 8800 with Windows Mobile 2003 Software for Pocket PCs Product Reference Guide* for more information.

Initiating a Network Connection

Before using the PPT8846, PPT 8860 or PPT 8866 terminal, set up the Spectrum24 network and/or Bluetooth connection. Refer to the *PPT 8800 with Windows Mobile 2003 Software for Pocket PCs Product Reference Guide* for setup instructions.

Scanning

The terminal has an integrated scanner which collects data by scanning bar codes. Refer to the *PPT 8800 with Windows Mobile 2003 Software for Pocket PCs Product Reference Guide* for information on configuring your terminal for scanning.

To scan bar codes:

1. Launch a scanning enabled application.
2. Aim the scanner at the bar code.

Q u i c k R e f e r e n c e

3. Press either the right, or left scan trigger. Ensure the red scan beam covers the entire bar code. The green scan LED lights and a beep sounds to indicate a successful decode.

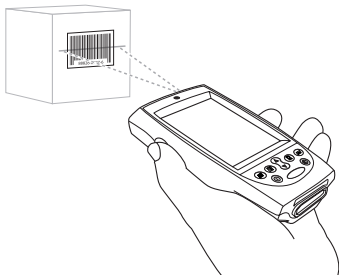

Using a Headset

Note: The audio connector does not support headsets with a microphone.

You can use a headset to listen to audio playback. To use a headset, plug the headset jack into the audio connector on the top of the terminal.

Ensure that the terminal's volume is set appropriately before putting the headset on.

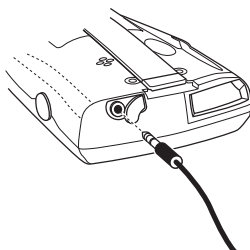

Resetting the Terminal



If the terminal stops responding to input, reset it.

Performing a Soft Reset

A soft reset restarts the terminal and saves all stored records and entries.

Caution: Files that remain open during a soft reset may not be retained.
DO NOT perform a soft reset if the terminal is suspended. Press the power button to wake the terminal.

To perform a soft reset on the Standard keypad, press the Enter and  keys while holding down either the left or right scan trigger and then releasing the keys.

To perform a soft reset on the 15-key keypad, press  and  keys while holding down either the left or right scan trigger and then releasing the keys.

Performing a Hard Reset

A hard reset also restarts the terminal, but erases all stored records and entries. *Therefore, never perform a hard reset unless a soft reset does not solve the problem.*

Note: You can restore any data previously synchronized with a computer during the next ActiveSync operation. Refer to the *PPT 8800 with Windows Mobile 2003 Software for Pocket PCs Product Reference Guide*.

To perform a hard reset:

1. Remove the battery cover.

Q u i c k R e f e r e n c e

2. While holding down the Function key, use the stylus to gently press the reset button.

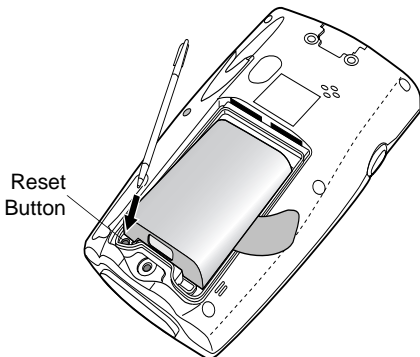

3. Release the Function key.
4. Replace the battery cover.
5. Press **Ⓜ**.
6. As the terminal initializes its unique Flash File system, the Symbol splash screen displays for about a minute.
7. See [Starting the Terminal on page 8](#) to perform an initial setup of the terminal.

Caution: With a hard reset, formats, preferences, and other settings are restored to their factory default settings.

Host Communications

The terminal can communicate with a host computer either directly through its communications port using the cradle, or wirelessly via the Spectrum24[®] wireless LAN or Bluetooth Wireless PAN. For more information on setting up and performing wireless communications with your terminal, refer to the *PPT 8800 with Windows Mobile 2003 Software for Pocket PCs Product Reference Guide*.



Note: ActiveSync software may be needed to use the Device with a desktop computer; and the Enterprise Customer may obtain ActiveSync from the following web site <http://www.microsoft.com/windowsmobile/resources/downloads/pocketpc/default.mspx> or from such other web sites as may be designated from time to time.

Using the Serial Charging Cable

To connect the serial charging cable for host communication:

1. Insert the cable into the bottom of the terminal.
2. Connect the other end of the cable into the serial port of the host computer.
3. Begin host communications as specified by your application.

Using the Cradle

The terminal can communicate with a host computer using the single-slot serial cradle, four-slot serial cradle and four-slot ethernet cradle. For more information, see the connection instructions in the cradle's Quick Reference Guide.

Communicating with Printers

To print to a standard printer:

1. Attach the Universal Cable Cup to the bottom of the terminal.
2. Attach the appropriate printer cable to the serial port in the bottom of the Universal Cable Cup.
3. Attach the other end of the cable to the data communications connector on the printer.
4. Run the application's print function.

To print from an IrDA-compliant printer:

1. Point the IrDA port on the back of the terminal at the IrDA port on the printer, at a maximum distance of 11.8 inches (0.3 meter).

Q u i c k R e f e r e n c e

2. Run the application's print function.

Note: The terminal must have software configured to communicate with the printer you are using.

Maintenance

- Do not scratch the screen. Use the supplied stylus or plastic tipped pens intended for use with a touch-sensitive screen. Never use a pen or pencil or other sharp object on the screen.
- Do not drop the terminal or subject it to strong impact.
- Do not use the terminal where there is a lot of dust and dirt.
- Do not leave the terminal in direct sunlight, in very high humidity, and near heat source.
- Do not use the terminal where there is water.
- If the surface of the screen becomes soiled, clean it with a soft cloth moistened with a diluted window-cleaning solution.
- Discard used lithium-ion battery according to regulations. Never put the terminal into a fire because it may explode.

Troubleshooting

Problem	Cause	Solution
Terminal does not turn on.	Battery not charged.	Charge or replace the battery in the terminal.
	Battery not installed properly.	Ensure battery is installed properly. See Installing the Battery on page 5 .
	System crash.	Perform a hard reset. See Performing a Hard Reset on page 16 .
Terminal doesn't recognize my handwriting.	Character strokes written incorrectly with the stylus.	For your terminal to recognize handwriting input with the stylus, characters must be written a certain way. Refer to the <i>PPT 8800 with Windows Mobile 2003 Software for Pocket PCs Product Reference Guide</i> for information about how to write character strokes.
	Character strokes written on the wrong part of the LCD screen.	Make the character strokes in the lower character entry area on the screen — not on the display part of the screen.
	Lower-case and upper-case letters, and numbers written on the wrong parts of the LCD screen.	Ensure you are writing letters and numbers in the correct part of the LCD screen.
Rechargeable lithium-ion battery did not charge.	Battery failed.	Replace battery. If your terminal still does not operate, try a soft reset, then a hard reset; see Resetting the Terminal on page 15 .
	Terminal removed from cradle while battery was charging.	Insert terminal in cradle and begin charging. The lithium-ion battery requires up to 2 1/2 hours to recharge fully. The larger capacity battery requires 5 hours to recharge fully.
Cannot see characters on display.	Terminal not powered on.	Press the Power key.
Communication with host fails while using the USB cable and Cable Cup.	Electrostatic discharge (ESD) may have caused USB connection to be inoperable.	Disconnect the USB cable from the Cable Cup and then reconnect.

Q u i c k R e f e r e n c e

Problem	Cause	Solution
Fail to communicate with IrDA printer.	Distance from printer is more than 0.3 meter (11.8 inches).	Bring the terminal closer to the printer and attempt communications again.
	Obstruction interfered with communication.	Check the path to ensure no objects were in the way.
	IrDA window is dirty or obstructed.	Gently clean the IrDA window using a tissue or other non-abrasive material. Do not spray any cleaner directly on the IrDA window.
	Application is not enabled to run IrDA printing.	Printer support must be included with the application to run IrDA printing on the terminal. See your System Administrator.
During data communication, no data was transmitted, or transmitted data was incomplete.	Terminal removed from cradle during communications.	Replace the terminal in the cradle and re-transmit.
	Incorrect cable configuration.	See your System Administrator.
	Communication software was incorrectly installed or configured.	Perform setup as described in the <i>PPT 8800 with Windows Mobile 2003 Software for Pocket PCs Product Reference Guide</i> .
No sound is audible.	Volume setting is low or turned off.	Check the System Volume slider in the <i>Sounds & Notifications</i> properties dialog box (under <i>Start - Settings</i>) to ensure the volume is set to an adequate level.
Terminal turns itself off.	Terminal is inactive.	Your terminal turns off after a period of inactivity. This period can be set from one to five minutes, in one-minute intervals. Check the <i>Power</i> dialog box (under <i>Start - Settings - System</i> tab), and change the setting if you need a longer delay before the automatic shutoff feature activates.
Terminal does not respond to a hard reset.	Battery cover is attached.	You must remove the battery cover before performing a hard reset.
	Battery is not charged.	Charge the terminal. See Charging the Battery on page 6.

Problem	Cause	Solution
Tapping the screen buttons or icons does not activate the corresponding feature.	LCD screen not calibrated correctly.	Calibrate the screen. See Calibrating the Screen on page 8.
A message appears stating that your terminal's memory is full.	Too many files stored on the terminal.	Delete unused memos and records. You can save these records on your computer.
	Memory allocation too low.	Adjust the memory allocation. Select <i>Start - Settings</i> , and select the <i>System</i> tab. Tap <i>Memory</i> icon and adjust the slider.
	Too many applications installed on the terminal.	If you have installed additional applications on your terminal, remove them to recover memory. Select <i>Start - Settings</i> , and select the <i>System</i> tab. Tap <i>Remove Programs</i> , select the unused program and tap Remove .
When receiving beamed data an out of memory message appears.	Not enough free memory available for receiving data.	Your terminal requires at least twice the amount of memory available as the data you are receiving. For example, if you are receiving a 30K application, you must have at least 60K free.
Beamed data does not transmit.	Terminals too close together.	Confirm that the terminals are 12" apart, and there is a clear path between the two devices.
	Insufficient room lighting.	Adjust the room lighting or move to a different location.
	IrDA window is dirty or obstructed.	Gently clean the IrDA window using a tissue or other non-abrasive material. Do not spray any cleaner directly on the IrDA window.

Q u i c k R e f e r e n c e

Problem	Cause	Solution
Your terminal does not accept scan input.	Scanning application is not loaded.	Verify that the unit is loaded with a scanning application. See your System Administrator.
	Unreadable bar code.	Ensure the symbol is not defaced.
	Distance between exit window and bar code is incorrect.	Ensure you are within proper scanning range.
	Terminal is not programmed for the bar code.	Ensure the terminal is programmed to accept the type of bar code you are scanning.
	Terminal is not programmed to generate a beep.	If you are expecting a beep on a good decode and don't hear one, check that the application is set to generate a beep on good decode.
	Battery is low.	If the scanner stops emitting a laser beam when you press the trigger, check your battery level. Note: If the scanner is still not reading symbols, contact your distributor or Symbol Technologies.
	Scan window is dirty or obstructed.	Gently clean the scan window using a tissue or other non-abrasive material. Do not spray any cleaner directly on the scanner window.
<i>Main Battery Very Low</i> message appears.	The capacity of the lithium-ion battery is low.	Replace battery with fully charged battery or re-charge the battery.
<i>Backup Battery Low</i> or <i>Backup Battery Very Low</i> message appears.	The capacity of the built-in backup battery is low.	Re-charge the main battery using the cradle or serial charging cable. DO NOT remove the battery from the terminal. Note: When the terminal is turned on for the first time, the backup battery message appears. Ignore this message because the backup battery has not yet been fully charged.



END-USER LICENSE AGREEMENT

- You have acquired a device ("DEVICE") that includes software licensed by Symbol from Microsoft Licensing Inc. or its affiliates ("MS"). Those installed software products of MS origin, as well as associated media, printed materials, and "online" or electronic documentation ("SOFTWARE") are protected by international intellectual property laws and treaties. The SOFTWARE is licensed, not sold. All rights reserved. SOFTWARE includes software already installed on the DEVICE ("DEVICE Software") and MS software contained on the CD-ROM disk ("Companion CD").
- IF YOU DO NOT AGREE TO THIS END USER LICENSE AGREEMENT ("EULA"), DO NOT USE THE DEVICE OR COPY THE SOFTWARE. INSTEAD, PROMPTLY CONTACT SYMBOL FOR INSTRUCTIONS ON RETURN OF THE UNUSED DEVICE(S) FOR A REFUND. ANY USE OF THE SOFTWARE, INCLUDING BUT NOT LIMITED TO USE ON THE DEVICE, WILL CONSTITUTE YOUR AGREEMENT TO THIS EULA (OR RATIFICATION OF ANY PREVIOUS CONSENT).

GRANT OF SOFTWARE LICENSE. This EULA grants you the following license:

- **DEVICE Software.** You may use the DEVICE Software as installed on the DEVICE.
- **COMPANION CD.** A Companion CD is included with your DEVICE, and you may install and use the Microsoft® ActiveSync® 3.7 component on one (1) or more computers to exchange information with one (1) or more computing devices that contain a compatible version of the Microsoft® Pocket PC Software 2002 operating system. For other software component(s) contained on the Companion CD, you may install and use such components only in accordance with the terms of the printed or online end user license agreement(s) provided with such component(s). In the absence of an end user license agreement for particular component(s) of the Companion CD, you may install and use only one (1) copy of such component(s) on the DEVICE or a single computer with which you use the DEVICE.
- **Microsoft® Outlook® 2002.** If Microsoft Outlook 2002 is included with your DEVICE, the following terms apply to your use of Microsoft Outlook 2002: (i) regardless of the information contained in the "Software Installation and Use" section of the online EULA you may install one (1) copy of Microsoft Outlook 2002 on one (1) computer to use, exchange data, share data, access and interact with the DEVICE, and (ii) the EULA for Microsoft Outlook 2002 is between Symbol and the end user - not between the PC manufacturer and end user.
- **Security Updates/Digital Rights Management.** Content providers are using the digital rights management technology contained in this SOFTWARE ("DRM") to protect the integrity of their content ("Secure Content") so that their intellectual property, including copyright, in such content is not misappropriated. Portions of this SOFTWARE and third party applications such as media players use DRM to play Secure Content ("DRM Software"). If the DRM SOFTWARE's security has been compromised, owners of Secure Content ("Secure Content Owners") may request that MS revoke the DRM SOFTWARE's right to copy, display and/or play Secure Content. Revocation does not alter the DRM SOFTWARE's ability to play unprotected content. A list of revoked DRM SOFTWARE is sent to your computer whenever you download a license for Secure Content from the Internet. You therefore agree that MS may, in conjunction with such license, also download revocation lists onto your computer on behalf of Secure Content Owners. MS will not retrieve any personally identifiable information, or any other information, from your computer by downloading such revocation lists. Secure Content Owners may also require you to upgrade some of the DRM components in this SOFTWARE ("DRM Upgrades") before accessing their content. When you attempt to play such content, MS DRM SOFTWARE will

Q u i c k R e f e r e n c e

notify you that a DRM Upgrade is required and then ask for your consent before the DRM Upgrade is downloaded. Third party DRM Software may do the same. If you decline the upgrade, you will not be able to access content that requires the DRM Upgrade; however, you will still be able to access unprotected content and Secure Content that does not require the upgrade.

DESCRIPTION OF OTHER RIGHTS AND LIMITATIONS.

- **Speech/Handwriting Recognition.** If the SOFTWARE includes speech and/or handwriting recognition component(s), you should understand that speech and handwriting recognition are inherently statistical processes and that errors can occur in the component's recognition of your handwriting, and the final conversion into text. Neither Symbol nor its suppliers shall be liable for any damages arising out of errors in the speech and handwriting recognition process.
- **Limitations on Reverse Engineering, Decompilation and Disassembly.** You may not reverse engineer, decompile, or disassemble the SOFTWARE, except and only to the extent that such activity is expressly permitted by applicable law notwithstanding this limitation.
- **Single DEVICE.** The DEVICE Software is licensed with the DEVICE as a single integrated product. The DEVICE Software installed in read only memory ("ROM") of the DEVICE may only be used as part of the DEVICE.
- **Single EULA.** The package for the DEVICE may contain multiple versions of this EULA, such as multiple translations and/or multiple media versions (e.g., in the user documentation and in the software). Even if you receive multiple versions of the EULA, you are licensed to use only one (1) copy of the DEVICE Software.
- **NO RENTAL.** Except if specifically authorized by Symbol for leased hardware, you may not rent, lease, or lend the SOFTWARE.

APPROVED ADDITIONAL TEXT IF THE DEVICE IS LEASED

LEASED HARDWARE. In the event that you receive the DEVICE under the terms of a lease from Symbol or Symbol's third-party representative, the following additional terms shall apply: (i) you may not transfer the SOFTWARE to another user as part of the transfer of the DEVICE, whether or not a permanent transfer of the SOFTWARE with the DEVICE is otherwise allowed in this EULA; (ii) your rights with respect to any SOFTWARE upgrades shall be as determined by the lease you signed for the DEVICE; and (iii) you may not use the SOFTWARE after your lease terminates, unless you purchase the DEVICE from Symbol.]

- **Software Transfer.** You may permanently transfer all of your rights under this EULA only as part of a sale or transfer of the DEVICE, provided you retain no copies, you transfer all of the SOFTWARE (including all component parts, the media and printed materials, any upgrades, this EULA and, if applicable, the Certificate(s) of Authenticity), and the recipient agrees to the terms of this EULA. If the SOFTWARE is an upgrade, any transfer must include all prior versions of the SOFTWARE.
- **Termination.** Without prejudice to any other rights, Symbol or MS may terminate this EULA if you fail to comply with the terms and conditions of this EULA. In such event, you must destroy all copies of the SOFTWARE and all of its component parts.

UPGRADES AND RECOVERY MEDIA.

- **DEVICE Software.** If the DEVICE Software is provided by Symbol separate from the DEVICE on media such as a ROM chip, CD ROM disk(s) or via web download or other means, and is labeled "For Upgrade Purposes Only" you may install one (1)



copy of such DEVICE Software onto the DEVICE as a replacement copy for the existing DEVICE Software, and use it in accordance with this EULA.

- **COMPANION CD.** If any software component(s) is provided by Symbol separate from the DEVICE on CD ROM disk(s) or via web download or other means, and labeled "For Upgrade Purposes Only", you may (i) install and use one (1) copy of such component(s) on the computer(s) you use to exchange data with the DEVICE as a replacement copy for the existing Companion CD component(s).

COPYRIGHT. All title and intellectual property rights in and to the SOFTWARE (including but not limited to any images, photographs, animations, video, audio, music, text and "applets," incorporated into the SOFTWARE), the accompanying printed materials, and any copies of the SOFTWARE, are owned by MS or its suppliers (including Microsoft Corporation). You may not copy the printed materials accompanying the SOFTWARE. All title and intellectual property rights in and to the content which may be accessed through use of the SOFTWARE is the property of the respective content owner and may be protected by applicable copyright or other intellectual property laws and treaties. This EULA grants you no rights to use such content. All rights not specifically granted under this EULA are reserved by MS and its suppliers (including Microsoft Corporation).

EXPORT RESTRICTIONS. You acknowledge that SOFTWARE is subject to U.S. export jurisdiction. You agree to comply with all applicable international and national laws that apply to the SOFTWARE, including the U.S. Export Administration Regulations, as well as end-user, end-use and destination restrictions issued by U.S. and other governments. For additional information, see <http://www.microsoft.com/exporting/>.

PRODUCT SUPPORT. Product support for the SOFTWARE is not provided by MS, its parent corporation, Microsoft Corporation, or their affiliates or subsidiaries. For product support, please refer to Symbol support number provided in the documentation for the DEVICE. Should you have any questions concerning this EULA, or if you desire to contact Symbol for any other reason, please refer to the address provided in the documentation for the DEVICE.

NO LIABILITY FOR CERTAIN DAMAGES. EXCEPT AS PROHIBITED BY LAW, MS SHALL HAVE NO LIABILITY FOR ANY INDIRECT, SPECIAL, CONSEQUENTIAL OR INCIDENTAL DAMAGES ARISING FROM OR IN CONNECTION WITH THE USE OR PERFORMANCE OF THE SOFTWARE. THIS LIMITATION SHALL APPLY EVEN IF ANY REMEDY FAILS OF ITS ESSENTIAL PURPOSE.

FOR APPLICABLE LIMITED WARRANTIES AND SPECIAL PROVISIONS PERTAINING TO YOUR PARTICULAR JURISDICTION, PLEASE REFER TO YOUR WARRANTY BOOKLET INCLUDED WITH THIS PACKAGE OR PROVIDED WITH THE SOFTWARE PRINTED MATERIALS.

Ergonomic Recommendations

Caution: Even the best-designed products can be a potential source of injury/illness if used incorrectly. In order to avoid or minimize risk of ergonomic injury, follow the general recommendations below. Consult with your local Health & Safety Manager to ensure that you are meeting your company's safety programs to prevent employee injury.

- Reduce or eliminate repetitive motion
- Maintain a natural position and avoid awkward positions

Q u i c k R e f e r e n c e

- Reduce or eliminate excessive force
- Keep objects that are used frequently within easy reach
- Perform tasks at correct heights
- Reduce or eliminate vibration
- Reduce or eliminate direct pressure
- Provide adjustable workstations
- Provide adequate clearance
- Provide a suitable working environment
- Improve work procedures
- Take periodic rest breaks.

Bluetooth Information

For PPT8860: This product contains Bluetooth complementary subsystems B00838 and B01108. For PPT8866: This product contains Bluetooth complementary subsystems B00813 and B001285.

Regulatory Information

All Symbol devices are designed to be compliant with rules and regulations in locations they are sold and will be labeled as required.

Any changes or modifications to Symbol Technologies equipment, not expressly approved by Symbol Technologies, could void the user's authority to operate the equipment.

Radio Modules

The PPT 8846 contains an approved radio module. This module is identified below. Symbol Compact Flash RLAN (11 Mbps DSSS) radio card, Type: LA-4137.

The PPT 8860 contains an approved radio module. This module is identified below. Socket Compact Flash Bluetooth radio card, Model # 8510-00159G.

The PPT 8866 contains an approved radio modules. This modules are identified below.

Symbol Compact Flash RLAN (11 Mbps DSSS) radio card, Type: LA-4137
Symbol Bluetooth module, Type: 21-64381.

Applying the Regulatory Country Stamp

A regulatory label is applied to signify the device is approved for use in the following countries: United States, Canada, Australia, Japan & Europe.

Note: Europe includes, Austria, Belgium, Croatia, Denmark, Estonia, Finland, France, Germany, Greece, Iceland, Ireland, Italy, Liechtenstein, Luxembourg, Netherlands, Norway, Portugal, Spain, Sweden, Switzerland, United Kingdom.

In addition to the list above other countries may require a regulatory stamp to be affixed to the product. Please refer to www.symbol.com for the list of countries where mandatory stamps are required. For countries that require regulatory label, a sheet



of stamps may be enclosed within the package. If the appropriate stamp is not provided, please contact your supplier. To apply the country stamp:

1. Peel the stamp appropriate to the country where this device is to be used.
2. Apply the country stamp in the space provided in the battery well.

Operation of the device without a regulatory label or the correct country Stamp is illegal.

Laser Devices

Symbol devices using lasers comply with US 21CFR1040.10, and IEC825-1:1993, EN60825-1:1994+A11:1996. The laser classification is marked on one of the labels on the device.

Class 1 Laser devices are not considered to be hazardous when used for their intended purpose. The following statement is required to comply with US and international regulations:

Caution: Use of controls, adjustments or performance of procedures other than those specified herein may result in hazardous laser light exposure.

Class 2 laser scanners use a low power, visible light diode. As with any very bright light source, such as the sun, the user should avoid staring directly into the light beam. Momentary exposure to a Class 2 laser is not known to be harmful.

Scanning Label

AVOID EXPOSURE - LASER LIGHT IS EMITTED FROM THIS APERTURE
EVITER TOUTE EXPOSITION - LUMIERE LASER EMIS PAR CETTE OUVERTURE

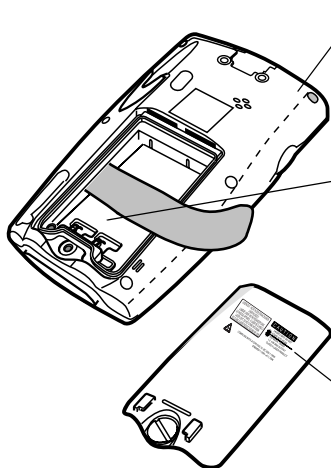

DANGER - LASER LIGHT WHEN OPEN. AVOID DIRECT EYE EXPOSURE. ATTENTION - LUMIERE LASER EN CAS D'OUVERTURE. EXPOSITION DANGEREUSE AU FAISCEAU
VORSICHT - LASERLICHT, WENN ABDECKUNG GEÖFFNET. NICHT STRAHL AUSSETZEN. SEE QUICK REFERENCE GUIDE FOR PATENT INFORMATION

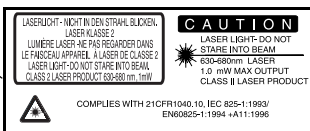

Q u i c k R e f e r e n c e

In accordance with Clause 5, IEC 825 and EN60825, the following information is provided to the user:



ENGLISH

CLASS 1 CLASS 1 LASER PRODUCT
LASER LIGHT
DO NOT STARE INTO BEAM
CLASS 2 CLASS 2 LASER PRODUCT

HEBREW

מוצר לייזר רמה 1 רמה 1
אור לייזר רמה 2
אין להביט אל תוך הזרם
מוצר לייזר רמה 2

DANISH / DANSK

KLASSE 1 KLASSE 1 LASERPRODUKT
LASERLYF
SE IKKE IND I STRÅLEN
KLASSE 2 LASERPRODUKT

ITALIAN / ITALIANO

CLASSE 1 PRODOTTO AL LASER DI CLASSE 1
LUCI LASER
CLASSE 2 NON FISSARE IL RAGGIOPRODOTTO
AL LASER DI CLASSE 2

DUTCH / NEDERLANDS

KLASSE 1 KLASSE-1 LASERPRODUKT
LASERLICHT
NIET IN STRAAL STAREN
KLASSE-2 LASERPRODUKT

NORWEGIAN / NORSK

KLASSE 1 LASERPRODUKT, KLASSE 1
KLASSE 2 LASERLYS IKKE STIRR INN I LYSSTRÅLEN
LASERPRODUKT, KLASSE 2

FINNISH / SUOMI

LUOKKA 1 LUOKKA 1 LASERTUOTE
LASERVALO
ÄLÄ TUJOTA SÄDETTÄ
LUOKKA 2 LASERTUOTE

PORTUGUESE / PORTUGUÊS

CLASSE 1 PRODUTO LASER DA CLASSE 1
CLASSE 2 LUZ DE LASER NÃO FIXAR O RAIOS LUMINOSOS
PRODUTO LASER DA CLASSE 2

FRENCH / FRANÇAIS

CLASSE 1 PRODUIT LASER DE CLASSE 1
LUMIERE LASER
CLASSE 2 NE PAS REGARDER LE RAYON FIXEMENT
PRODUIT LASER DE CLASSE 2

SPANISH / ESPAÑOL

CLASE 1 PRODUCTO LASER DE LA CLASE 1
LUZ LASER
CLASE 2 NO MIRE FIJAMENTE EL HAZ
PRODUCTO LASER DE LA CLASE 2

GERMAN / DEUTSCH

KLASSE 1 LASERPRODUKT DER KLASSE 1
KLASSE 2 LASERSTRAHLEN
NICHT DIREKT IN DEN LASERSTRAHL SCHAUEN
LASERPRODUKT DER KLASSE 2

SWEDISH / SVENSKA

KLASS 1 LASERPRODUKT KLASS 1
KLASS 2 LASERLJUS STIRRA INTE MOT STRÅLEN
LASERPRODUKT KLASS 2

Power Supply

Note: Use only a Symbol-approved power supply (50-14000-107) output rated 9.0 Vdc and minimum 2.0 A. The power supply is certified to EN60950 with SELV outputs.

Hinweis: Benutzen Sie nur eine Symbol Technologies genehmigt Stromversorgung (50-14000-107) in den Ausgabe: 9.0 Vdc und minimum 2.0 A. Die Stromversorgung ist bescheinigt nach EN60950 mit SELV Ausgaben.



FCC RF Exposure Guidelines

This device was tested for typical body-worn operations with the holster providing a minimal spacing of 2.0 cm from the body to the back of the terminal/antenna. To maintain compliance with FCC RF exposure compliance requirements, use only belt-clips, holsters, or similar accessories that maintain a 2.0 cm separation distance between the user's body and the back of the terminal, including the antenna. The use of third-party belt-clips, holsters, and similar accessories should not contain metallic components in its assembly. The use of these accessories that do not satisfy these requirements may not comply with FCC RF exposure compliance requirements, and should be avoided.

This equipment generates and radiates radio-frequency energy. To comply with FCC RF exposure compliance requirements, the following antenna installation and device operating configurations must be satisfied:

- (1) Users are not permitted to make changes or modify the system in any way, and
- (2) connecting external antennas to the card is prohibited. This device and its antenna must not be co-located or operated with any other antenna or transmitter.

Radio Frequency Interference Requirements



Note: This equipment has been tested and found to comply with the limits for a Class B digital device, pursuant to Part 15 of the FCC rules. These limits are designed to provide reasonable protection against harmful interference in a residential

installation. This equipment generates, uses and can radiate radio frequency energy and, if not installed and used in accordance with the instructions, may cause harmful interference to radio communications. However there is no guarantee that interference will not occur in a particular installation. If this equipment does cause harmful interference to radio or television reception, which can be determined by turning the equipment off and on, the user is encouraged to try to correct the interference by one or more of the following measures:

- Reorient or relocate the receiving antenna
- Increase the separation between the equipment and receiver
- Connect the equipment into an outlet on a circuit different from that to which the receiver is connected
- Consult the dealer or an experienced radio/TV technician for help.

This device complies with FCC Part 15. Operation is subject to the following two conditions:

- (1) This device may not cause harmful interference and
- (2) This device must accept any interference received, including interference that may cause undesired operation.

Radio Frequency Interference Requirements - Canada

This device complies with RSS 210 of Industry & Science Canada. Operation is subject to the following two conditions: (1) this device may not cause harmful interference and (2) this device must accept any interference received, including interference that may cause undesired operation.

This Class B digital apparatus complies with Canadian ICES-003.

Cet appareil numérique de la classe B est conforme à la norme NMB-003 du Canada.

Label Marking: The Term "IC:" before the radio certification only signifies that Industry Canada technical specifications were met.

To prevent radio interference to the licensed service, this device is intended to be operated indoors and away from windows to provide maximum shielding. Equipment (or its transmit antenna) that is installed outdoors is subject to licensing.



Marking and European Economic Area (EEA)

RLAN's (2.4GHz) for use through the EEA have the following restrictions:

- Maximum radiated transmit power of 100 mW EIRP in the frequency range 2.400 -2.4835 GHz
- France, equipment is restricted to 2.4465 -2.4835 GHz frequency range
- Belgium outside usage, the equipment is restricted to 2.460 -2.4835 GHz frequency range
- Italy requires a user license for outside usage.

Bluetooth for use through the EEA have the following restrictions:

- Maximum radiated transmit power of 10mW EIRP in the frequency range 2.400 -2.4835 GHz
- Belgium outside usage, the equipment is restricted to 2.460 -2.4835 GHz frequency range
- Italy requires a user license for outside usage.

Statement of Compliance

Symbol Technologies, Inc., hereby, declares that this device is in compliance with the essential requirements and other relevant provisions of Directives 1999/5/EC, 89/336/EEC and 73/23/EEC. Declaration of Conformities may be obtained from <http://www2.symbol.com/doc/>.

Other Countries

Mexico -	Restrict Frequency Range to: 2.450 - 2.4835 GHz.
Israel -	Restrict Frequency Range to: 2.418 - 2.457 GHz.
Sri Lanka-	Restrict Frequency Range to: 2.400 - 2.430 GHz.



Hazardous Location Usage

For specific PPT88XX Hazardous Location models:

A. "THIS EQUIPMENT IS SUITABLE FOR USE IN CLASS I, DIVISION 2, GROUPS A, B, C, AND D OR NON-HAZARDOUS LOCATIONS ONLY."

B. "WARNING! EXPLOSION HAZARD! SUBSTITUTION OF COMPONENTS MAY IMPAIR SUITABILITY FOR CLASS I, DIVISION 2."

Battery Information

Symbol rechargeable battery packs are designed and constructed to the highest standards within the industry.

However, there are limitations to how long your battery can operate or be stored before needing replacement. Many factors affect the actual life cycle of your battery pack, such as heat, cold, harsh environmental conditions and severe drops.

When batteries are stored over six (6) months, some irreversible deterioration in overall battery quality may occur. Store your batteries discharged in a dry, cool place, removed from the equipment to prevent loss of capacity, rusting of metallic parts and electrolyte leakage. When storing batteries for one year or longer, they should be charged and discharged at least once a year. If an electrolyte leakage is observed, avoid any contact with affected area and properly dispose of the battery.

An indication that your Symbol battery needs replacement is when normal run time begins to diminish. When you consistently experience significant loss of run time, replace your battery.

Standard warranty period for all Symbol batteries is 30 days, regardless if the battery was purchased separately or included as part of the mobile computer or bar code scanner.

For more information on Symbol batteries, please visit <http://mysymbolcare.symbol.com/battery/batbasics1.html>

Warranty

(A) Warranty Symbol Technologies (hereafter “Seller”) hardware Products are warranted against defects in workmanship and materials for a period of twelve (12) months from the date of shipment, unless otherwise provided by Seller in writing, provided the Product remains unmodified and is operated under normal and proper conditions. Warranty provisions and durations on software, integrated installed systems, Product modified or designed to meet specific customer specifications (“Custom Products”), remanufactured products, and reconditioned or upgraded products, shall be as provided in the applicable Product specification in effect at the time of purchase or in the accompanying software license.

(B) Spare Parts Spare parts (i.e. parts, components, or subassemblies sold by Seller for use in the service and maintenance of Products) are warranted against defects in workmanship and materials for a period of thirty (30) days from the date of shipment. Spare parts may be new or originate from returned units under the conditions set forth in subsection D below.

(C) Repair of Symbol-branded hardware For repairs on Symbol-branded hardware Products under this Agreement, including repairs covered by warranty, the repair services provided are warranted against defects in workmanship and materials on the repaired component of the Product for a period of thirty (30) days from the shipment date of the repaired Product, or until the end of the original warranty period, whichever is longer.

(D) Product Service Products may be serviced or manufactured with parts, components, or subassemblies that originate from returned products and that have been tested as meeting applicable specifications for equivalent new material and Products. The sole obligation of Seller for defective hardware Products is limited to repair or replacement (at Seller’s option) on a “return to service depot” basis with prior Seller authorization. Customer is responsible for shipment to the Seller and assumes all costs and risks associated with this transportation; return shipment to the Customer will be at Seller’s expense. Customer shall be responsible for return shipment charges for product returned where Seller determines there is no defect (“No Defect Found”), or for product returned that Seller determines is not eligible for warranty repair. No charge will be made to Buyer for replacement parts for warranty repairs. Seller is not responsible for any damage to or loss of any software programs, data or removable data storage media, or the restoration or reinstallation of any software programs or data other than the software, if any, installed by Seller during manufacture of the Product.

(E) Original Warranty Period Except for the warranty applying solely to the repaired component arising from a repair service as provided in Section C above, the aforementioned provisions do not extend the original warranty period of any Product that had either been repaired or replaced by Seller.

(F) Warranty Provisions The above warranty provisions shall not apply to any Product (i) which has been repaired, tampered with, altered or modified, except by Seller’s authorized service personnel; (ii) in which the defects or damage to the Product result from normal wear and tear, misuse, negligence, improper storage, water or other liquids, battery leakage, use of parts or accessories not approved or supplied by Symbol, or failure to perform operator handling and scheduled maintenance instructions supplied by Seller; (iii) which has been subjected to unusual physical or electrical stress, abuse, or accident, or forces or exposure beyond normal use within the specified operational and environmental parameters set forth in the applicable Product specification; nor shall the above warranty provisions apply to any expendable or consumable items, such as batteries, supplied with the Product.

EXCEPT FOR THE WARRANTY OF TITLE AND THE EXPRESS WARRANTIES STATED ABOVE, SELLER DISCLAIMS ALL WARRANTIES ON PRODUCTS FURNISHED HEREUNDER INCLUDING ALL IMPLIED WARRANTIES OF MERCHANTABILITY AND FITNESS FOR A PARTICULAR USE. ANY IMPLIED WARRANTIES THAT MAY BE IMPOSED BY LAW ARE LIMITED IN DURATION TO THE LIMITED WARRANTY PERIOD. SOME STATES OR COUNTRIES DO NOT ALLOW A LIMITATION ON HOW LONG AN IMPLIED WARRANTY LASTS OR THE EXCLUSION OR LIMITATION OF INCIDENTAL OR CONSEQUENTIAL DAMAGES FOR CONSUMER PRODUCTS. IN SUCH STATES OR COUNTRIES, FOR SUCH PRODUCTS, SOME EXCLUSIONS OR LIMITATIONS OF THIS LIMITED WARRANTY MAY NOT APPLY.

The stated express warranties are in lieu of all obligations or liabilities on the part of Seller for damages, including but not limited to, special, indirect or consequential damages arising out of or in connection with the use or performance of the Product or service. Seller’s liability for damages to Buyer or others resulting from the use of any Product or service furnished hereunder shall in no way exceed the purchase price of said Product or the fair market value of said service, except in instances of injury to persons or property.

Service Information

Before you use the unit, it must be configured to operate in your facility's network and run your applications.

If you have a problem running your unit or using your equipment, contact your facility's Technical or Systems Support. If there is a problem with the equipment, they will contact the Symbol Support Center:

United States	1-800-653-5350 1-631-738-2400	Canada	905-629-7226
United Kingdom	0800 328 2424	Asia/Pacific	337-6588
Australia	1-800-672-906	Austria/Österreich	1-505-5794-0
Denmark/Danmark	7020-1718	Finland/Suomi	9 5407 580
France	01-40-96-52-21	Germany/Deutschland	6074-49020
Italy/Italia	2-484441	Mexico/México	5-520-1835
Netherlands/Nederland	315-271700	Norway/Norge	+47 2232 4375
South Africa	11-8095311	Spain/España	91 324 40 00 Inside Spain
Sweden/Sverige	84452900		+34 91 324 40 00 Outside Spain
Latin America Sales Support	1-800-347-0178 Inside US +1-954-255-2610 Outside US		
Europe/Mid-East Distributor Operations	Contact local distributor or call +44 118 945 7360		

For the latest version of this guide go to: <http://www.symbol.com/manuals>.



72-63153-03
Revision A - December 2003